

Page 2

AX11015

Transformer and RJ45

Resister for Setting

24C02 EEPROM

Connector for
DOCD Tools

8Pin Connector for
Flash Download

Status LED

Reset

Page 3

POWER
Input

UART Transceiver
and DB9M

Page 4

SRAM
FLASH

ASIX ELECTRONICS CORPORATION

Title

AX11005_AP1_RS232_to_Ethernet

Size

Document Number

Rev

A

AX11005_AP1_RS232_to_Ethernet.DSN

1.01

Date:

Monday, July 10, 2006

Sheet

1

of

5

16Pin Connector for Flash Download

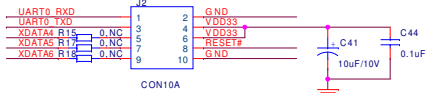

24C02

Address : 000

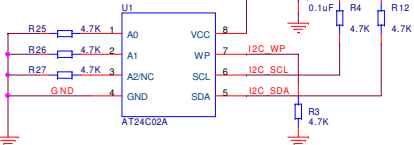

Reset

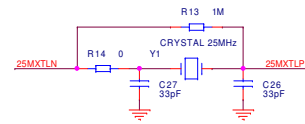
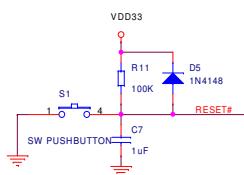

Transformer and RJ45

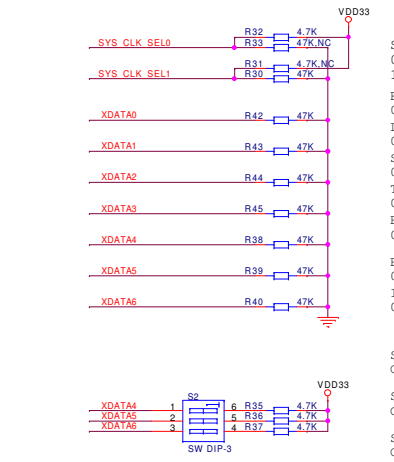
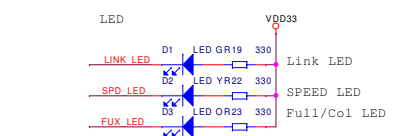
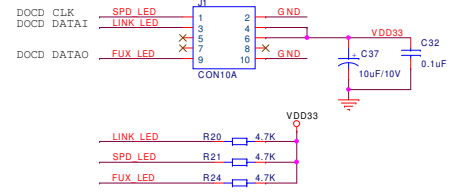
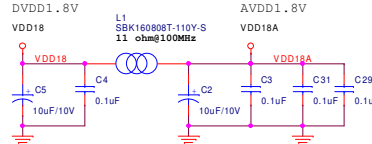
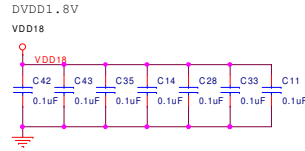
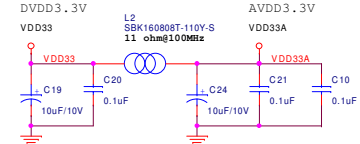
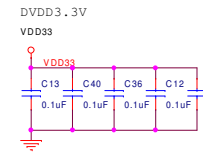
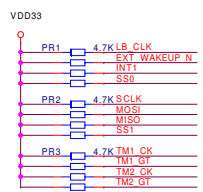
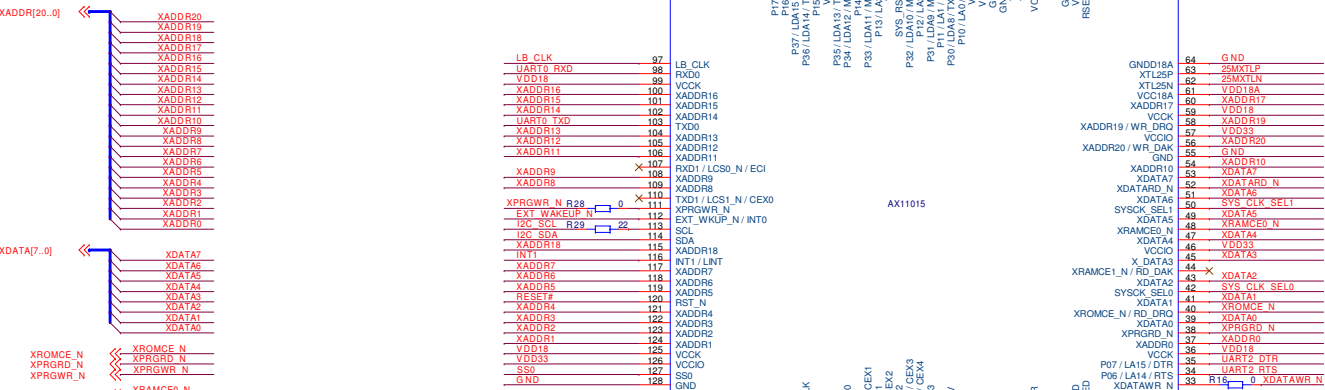
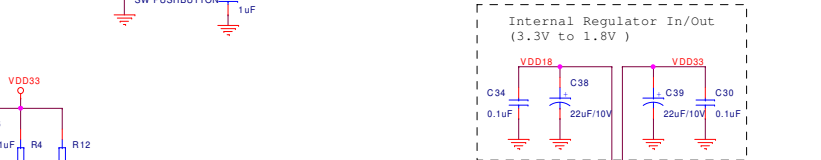
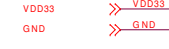
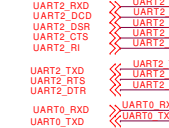
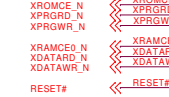
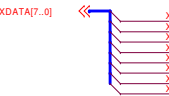
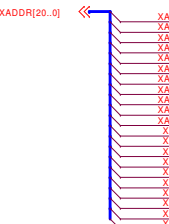
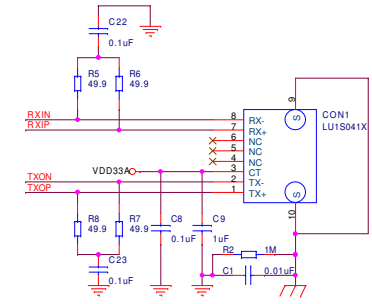

Setting

System CLK Select
 00 : 25MHz 01 : 50MHz (V)
 10 : Don't use 11 : 100MHz

Ext_Prog_Sram_En
 0 : Disable (V) 1 : Enable

Local Bus Mode
 0 : Master (V) 1 : Slave

Sync Bus
 0 : Async (V) 1 : Sync

Test SpeedUp
 0 : Normal (V) 1 : Enable

Burn Flash En
 0 : Disable (V) 1 : Enable

Burn Flash 921K
 0 : 115200 1 : 921K (V)

ICZ Boot Disable
 0 : Normal (V) 1 : Disable

S2.1-6 Burn Flash En
 On : Enable Off : Disable

S2.2-5 Burn Flash 921K
 On : 921K Off : 115200

S2.3-4 I2C Boot Disable
 On : Disable Off : Normal

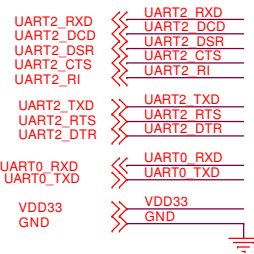

S3 : Select UART0 for Flash download
 S3 : Select UART2 for High speed UART

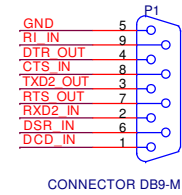
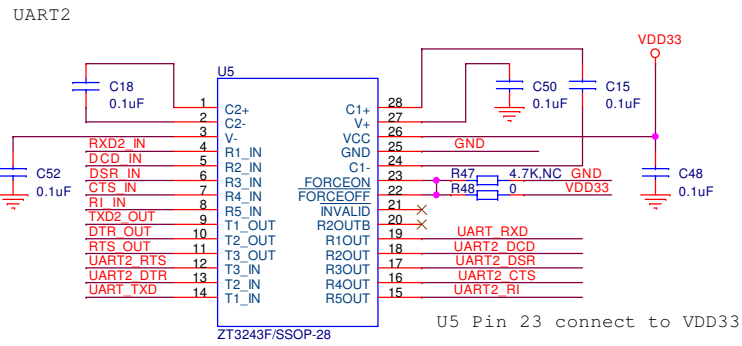
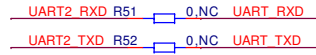
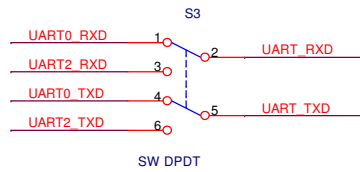

Option for RJ45 CNN

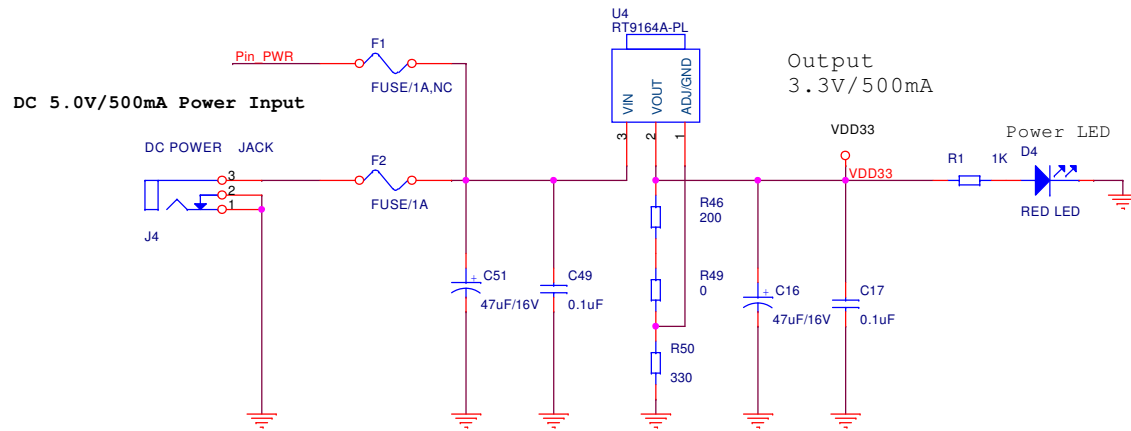
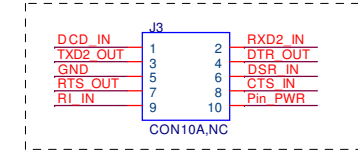

| | | |
|------------------------------|-----------------------------------|--------------|
| ASIX ELECTRONICS CORPORATION | | |
| Title | RS232 transceiver and power | |
| Size | Document Number | Rev |
| B | AX11015_AP1_RS232_to_Ethernet.DSN | 1.01 |
| Date: | Monday, July 10, 2006 | Sheet 3 of 5 |

V1.00 Init

V1.01

R48 Change to 4.7K,NC

U5 Pin 22 short to U5 Pin23.

ASIX ELECTRONICS CORPORATION

Title

History

Size

Document Number

Rev

A

AX11015_AP1_RS232_to_Ethernet.DSN

1.01

Date:

Monday, July 10, 2006

Sheet

3

of 5

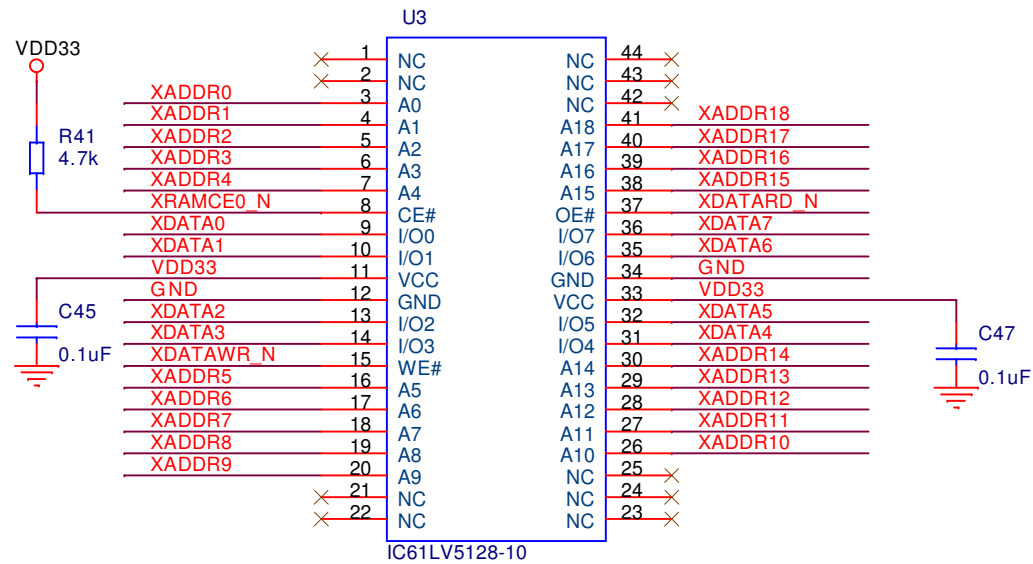
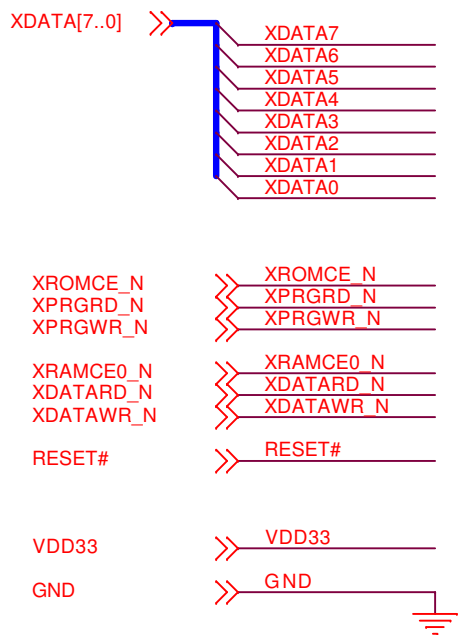
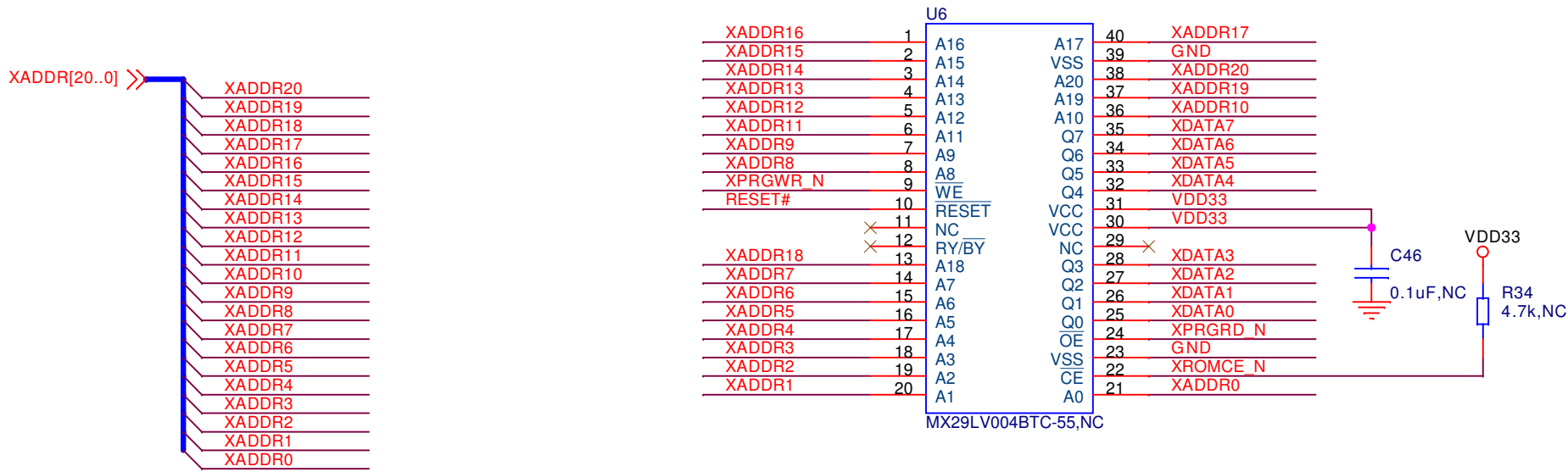

| | | |
|--------------------------------|--|-------------|
| ASIX ELECTRONICS CORPORATION | | |
| Title Flash and SRAM | | |
| Size A | Document Number AX11015_AP1_RS232_to_Ethernet.DSN | Rev 1.01 |
| Date: Monday, July 10, 2006 | Sheet 4 | of 5 |